

Feb. 2025



# **SCA16GU03C2F1C-56B**

**288-Pin DDR5 Unbuffered DIMM(X64,Non-ECC)  
EU RoHS Compliant**

## **Data Sheet**

**Rev. A**

Revision History		
Date	Revision	Subjects (major changes since last revision)
2025-02	A	Initial Release

**We Listen to Your Comments**

Any information within this document that you feel is wrong, unclear or missing at all? Your feedback will help us to continuously improve the quality of this document. Please send your proposal (including a reference to this document) to: [info@unisemicon.com](mailto:info@unisemicon.com)

# Contents

Contents.....	3
1 Overview.....	4
1.1 Features.....	4
1.2 Description.....	5
2 Pin Configurations.....	6
2.1 Pin Configurations.....	6
2.2 Pin Descriptions.....	8
3 General Description.....	10
3.1 General Description.....	10
3.2 Power Management Integrated Circuit Operation.....	11
3.3 SPD EEPROM HUB Operation.....	12
3.4 Function Block Diagram.....	13
3.5 DQ Map.....	14
4 Electrical Characteristics.....	15
4.1 AC and DC Operation Conditions.....	15
4.2 Module and Component Speed Grades.....	17
4.3 $I_{DD}$ Specifications.....	18
5 Package Dimensions.....	19
List of Figures.....	20
List of Tables.....	21

# 1 Overview

This chapter gives an overview of the 288-pin DDR5 UDIMM product family and describes its main characteristics.

## 1.1 Features

- 288-Pin PC5-5600 DDR5 UDIMM
- On-DIMM SPD EEPROM with hub function and integrated temperature sensor (TS)
- On-DIMM Power management integrated circuit (PMIC)
- Frequency/CAS latency: 0.357ns @ CL = 46 (DDR5-5600)
- VDD = VDDQ = 1.1V
- VPP = 1.8V
- On-die, internal, adjustable VREF generation for DQ, CA, CS
- 32 internal banks: 8 groups of 4 banks each
- 16n-bit prefetch architecture
- Gold edge contacts
- Halogen-free
- Fly-by topology
- Terminated clock, control, command and address bus
- Anti-Sulfurated Option

**Table 1 - Module Performance Table**

UnilC Speed Code		-56B	Unit	Note
DRAM Speed Grade	DDR5	-5600		
CAS-RCD-RP latencies		-46-45-45	$t_{CK}$	
Min. RAS-CAS-Delay	$t_{RCD}$	16	ns	
Min. Row Precharge Time	$t_{RP}$	16	ns	
Min. Row Active Time	$t_{RAS}$	32	ns	
Min. Row Cycle Time	$t_{RC}$	48	ns	

## 1.2 Description

The UniIC 16GB module family are UDIMM with 31.25mm height based on DDR5 technology.  
DIMMs intended for mounting into 288-pin connector sockets.



**Table 2 - Ordering Information**

Product Type	Compliance Code <sup>1)</sup>	Description	SDRAM Technology
<b>PC5-5600 (46-45-45)</b>			
SCA16GU03C2F1C-56B	16GB 1R×8 PC5-5600-46-45-45	1Rank	16Gbit (×8)

- 1) This describes the speed grade, for example "PC5-5600-46-45-45" where 5600 means DIMM modules with 5600MT/s data rate and "46-45-45" means Column Address Strobe (CAS) latency=46, Row Column Delay (RCD) latency = 45 and Row Precharge (RP) latency = 45.

**Table 3 - Address Format**

<b>DIMM Density</b>	<b>16GB(1Rx8,x64)</b>
<b>Row address</b>	64K A[15:0]
<b>Column address</b>	1K A[9:0]
<b>Device bank group address</b>	8 BG[2:0]
<b>Device bank address per group</b>	4 BA[1:0]
<b>Device configuration</b>	16Gb(2Gx8)
<b>Device Quantity</b>	8

## 2 Pin Configurations

### 2.1 Pin Configurations

The pin configuration of the 288-Pin UDIMM is listed by function in **Table 4** (288 pins).

**Table 4 - Pin Configuration UDIMM (288 pin)**

288-Pin DDR5 UDIMM Front							
Pin	Symbol	Pin	Symbol	Pin	Symbol	Pin	Symbol
1	VIN_BULK	37	DQ20_A	73	CK0_A_c	109	Vss
2	RFU	38	Vss	74	Vss	110	DQ5_B
3	RFU	39	DQ21_A	75	RFU	111	Vss
4	HSCCL	40	Vss	76	RFU	112	DQ8_B
5	HSDA	41	DQ24_A	77	Vss	113	Vss
6	Vss	42	Vss	78	CK0_B_t	114	DQ9_B
7	RFU	43	DQ25_A	79	CK0_B_c	115	Vss
8	Vss	44	Vss	80	Vss	116	DM1_B_n
9	DQ0_A	45	DM3_A_n	81	RFU	117	Vss
10	Vss	46	Vss	82	CA12_B	118	DQ12_B
11	DQ1_A	47	DQ28_A	83	Vss	119	Vss
12	Vss	48	Vss	84	CA10_B	120	DQ13_B
13	DQS0_A	49	DQ29_A	85	CA8_B	121	Vss
14	DQS0_A_t	50	Vss	86	Vss	122	DQ16_B
15	Vss	51	CB0_A	87	CA6_B	123	Vss
16	DQ4_A	52	Vss	88	CA4_B	124	DQ17_B
17	Vss	53	CB1_A	89	Vss	125	Vss
18	DQ5_A	54	Vss	90	CA2_B	126	DQS2_B_c
19	Vss	55	DQS4_A_c	91	CA0_B	127	DQS2_B_t
20	DQ8_A	56	DQS4_A_t	92	Vss	128	Vss
21	Vss	57	Vss	93	Cs0_B_n	129	DQ20_B
22	DQ9_A	58	Cs0_A_n	94	Vss	130	Vss
23	Vss	59	Vss	95	RESET_n	131	DQ21_B
24	DM1_A_n	60	CA0_A	96	Vss	132	Vss
25	Vss	61	CA2_A	97	CB0_B	133	DQ24_B
26	DQ12_A	62	Vss	98	Vss	134	Vss
27	Vss	63	CA4_A	99	CB1_B	135	DQ25_B
28	DQ13_A	64	CA6_A	100	Vss	136	Vss
29	Vss	65	Vss	101	DQ0_B	137	DM3_B_n
30	DQ16_A	66	CA8_A	102	Vss	138	Vss
31	Vss	67	CA10_A	103	DQ1_B	139	DQ28_B
32	DQ17_A	68	Vss	104	Vss	140	Vss
33	Vss	69	CA12_A	105	DQS0_B_c	141	DQ29_B
34	DQS2_A_c	70	RFU	106	DQS0_B_t	142	Vss
35	DQS2_A_t	71	Vss	107	Vss	143	RFU
36	Vss	72	CK0_A_t	108	DQ4_B	144	RFU

<b>288-Pin DDR5 UDIMM Back</b>							
<b>Pin</b>	<b>Symbol</b>	<b>Pin</b>	<b>Symbol</b>	<b>Pin</b>	<b>Symbol</b>	<b>Pin</b>	<b>Symbol</b>
145	VIN_BULK	181	DQ22_A	217	CK1_A_c	253	Vss
146	VIN_BULK	182	Vss	218	Vss	254	DQ7_B
147	PWR_GOOD	183	DQ23_A	219	RFU	255	Vss
148	HsA	184	Vss	220	RFU	256	DQ10_B
149	RFU	185	DQ26_A	221	Vss	257	Vss
150	Vss	186	Vss	222	CK1_B_t	258	DQ11_B
151	PWR_EN	187	DQ27_A	223	CK1_B_c	259	Vss
152	RFU	188	Vss	224	Vss	260	DQS1_B_c
153	Vss	189	DQS3_A_c	225	RFU	261	DQs1_B_t
154	DQ2_A	190	DQS3_A_t	226	RFU	262	Vss
155	Vss	191	Vss	227	Vss	263	DQ14_B
156	DQ3_A	192	DQ30_A	228	CA11_B	264	Vss
157	Vss	193	Vss	229	CA9_B	265	DQ15_B
158	DM0_A_n	194	DQ31_A	230	Vss	266	Vss
159	Vss	195	Vss	231	CA7_B	267	DQ18_B
160	DQ6_A	196	CB2_A	232	CA5_B	268	Vss
161	Vss	197	Vss	233	Vss	269	DQ19_B
162	DQ7_A	198	CB3_A	234	CA3_B	270	Vss
163	Vss	199	Vss	235	CA1_B	271	DM2_B_n
164	DQ10_A	200	ALERT_n	236	Vss	272	Vss
165	Vss	201	Vss	237	CS1_B_n	273	DQ22_B
166	DQ11_A	202	CS1_A_n	238	Vss	274	Vss
167	Vss	203	Vss	239	DQS4_B_c	275	DQ23_B
168	DQS1_A_c	204	CA1_A	240	DQS4_B_t	276	Vss
169	DQS1_A_t	205	CA3_A	241	Vss	277	DQ26_B
170	Vss	206	Vss	242	CB2_B	278	Vss
171	DQ14_A	207	CA5_A	243	Vss	279	DQ27_B
172	Vss	208	CA7_A	244	CB3_B	280	Vss
173	DQ15_A	209	Vss	245	Vss	281	DQS3_B_c
174	Vss	210	CA9_A	246	DQ2_B	282	DQS3_B_t
175	DQ18_A	211	CA11_A	247	Vss	283	Vss
176	Vss	212	Vss	248	DQ3_B	284	DQ30_B
177	DQ19_A	213	RFU	249	Vss	285	Vss
178	Vss	214	RFU	250	DM0_B_n	286	DQ31_B
179	DM2_A_n	215	Vss	251	Vss	287	Vss
180	Vss	216	CK1_A_t	252	DQ6_B	288	RFU

## 2.2 Pin Descriptions

Table 5 - Pin Descriptions

Symbol	Type	I/O Level	Description
CK[1:0]_A_t CK[1:0]_B_t CK[1:0]_A_c CK[1:0]_B_c	Input	VDDQ	Clock: CK_t and CK_c are differential clock inputs. All address and control input signals are sampled on the crossing of the positive edge of CK_t and negative edge of CK_c.
CA[12:0]_A CA[12:0]_B	DDR Input	VDDQ	Command/Address Inputs: CA signals provide the command and address inputs according to the Command Truth Table. Note: Since some commands are multi-cycle, the pins may not be interchanged between devices on the same bus. The address inputs also provide the op-code during MODE REGISTER SET commands.
CS[1:0]_A CS[1:0]_B	Input	VDDQ	Chip Select: All commands are masked when CS_n is registered HIGH. CS_n provides for external rank selection on systems with multiple ranks. CS_n is considered part of the command code. CS_n is also used to enter and exit the parts from power down mode and self refresh mode. While not in self refresh mode the CS_n input buffer operates with the same ODT and VREF parameters as configured by the CA_ODT strap setting or mode register. When in self refresh, the CS_n is a CMOS rail-to-rail signal with DC HIGH and LOW at 80% and 20% of VDD.
ALERT_n	Output	VDDQ	Alert: If there is an error in CRC, then ALERT_n drives LOW for the period time interval and returns HIGH. During connectivity test mode, this pin functions as an input. Usage of this signal is system-dependent. In the case where this pin is not connected, ALERT_n must be bonded to VDDQ on the system board.
RESET_n	CMOS Input	VDDQ	Active Low Asynchronous Reset: Reset is active when RESET_n is LOW, and inactive when RESET_n is HIGH. RESET_n must be HIGH during normal operation. RESET_n is a CMOS rail-to-rail signal with DC HIGH and LOW at 80% and 20% of VDDQ.
Power_Good	Input/Output	VDDQ	Power Good Indicator: Open drain output. The PMIC ensures this pin HIGH when VIN_Bulk input supply, as well as all enabled output buck regulators and all LDO regulators tolerance threshold is maintained as configured in the appropriate register. The PMIC drives this pin LOW when VIN_Bulk input goes below the threshold or when any of the enabled output buck regulator exceeds the thresholds configured in the appropriate register or when any LDO output regulator exceeds the threshold configured in the appropriate register. As an input, the PMIC disables its output regulator when this pin is LOW. The LDO outputs remain on.
HSCL	Input	VOUT_1.0V	Host Sideband Bus Clock: Bus clock used to strobe data into HUB device. When open drain, a pull-up resistor is required on the system motherboard.
HSDA	Input/Output	VOUT_1.0V	Host Sideband Bus Data: I2C/I3C-Basic data. When open drain, a pull-up resistor is required on the system motherboard.
HSA	Input	GND	Host Sideband Bus Device ID: Address input to a hub or other client device to distinguish between identical devices in the I3C basic address range. Tied to GND, HSA has different resistor values on the motherboard to identify DIMM slot address. Refer to the SPD Hub spec for more information.

Symbol	Type	I/O Level	Description
DQ[31:0]_A DQ[31:0]_B	Input/Output	VDDQ	Data Input/Output: Bidirectional data bus. If CRC is enabled via the mode register, then CRC code is added at the end of data burst. Any DQ from DQ0—DQ3 may indicate the internal VREF level during test via mode register setting MR4 A4 = HIGH. Refer to the vendor-specific data sheets to determine which DQ is used.
CB[7:0]_A CB[7:0]_B	Input/Output	VDDQ	ECC Check Bits Input/Output: Bidirectional data bus on UDIMM With ECC
DQS[4:0]_A_t DQS[4:0]_B_t  DQS[4:0]_A_c DQS[4:0]_B_c	Input/Output	VDDQ	Data Strobe: Output with read data, input with write data. Edge-aligned with read data, centered in write data. The data strobe DQS_t is paired with differential signals DQS_c, respectively, to provide differential pair signaling to the system during reads and writes. DDR5 SDRAM only supports differential data strobe. It does not support single-ended strobe.
DM[3:0]_A_n DM[3:0]_B_n	Input	VDDQ	Input Data Mask: DM_n is an input mask signal for write data. Input data is masked when DM_n is sampled LOW coincident with that input data during a write access. DM_n is sampled on both edges of DQS. For x8 device, the function of DM_n is enabled by MR5:OP[5] = 1.
PWR_EN	Input	3.3V	PMIC Enable. When this pin is high, the PMIC turns on the regulator. When this pin is low, the PMIC turns off the regulator. This signal is connected to PMIC's VR_EN pin.
VIN_BULK	Supply		External Power Supply: 5V, 4.25V (min), 5.5V (max)
VSS	Supply		Ground
RFU			Reserved for future use. No on DIMM electrical connection is present.
NC			No connect: No internal electrical connection is present.
NF			No function: May have internal connection present, but has no function.

## 3 General Description

### 3.1 General Description

High-speed DDR5 SDRAM modules use DDR5 SDRAM devices with four or eight internal memory bank groups. DDR5 SDRAM modules benefit from DDR5 SDRAM's use of a 16n-prefetch architecture with an interface designed to transfer two data words per clock cycle at the I/O pins. A single READ or WRITE operation for the DDR5 SDRAM effectively consists of a single 16n-bit-wide, eight-clock data transfer at the internal DRAM core and sixteen corresponding n-bit-wide, one-half-clock-cycle data transfers at the I/O pins.

DDR5 modules use two sets of differential signals (DQS\_t and DQS\_c) to capture data, and CK\_t and CK\_c to capture commands, addresses, and control signals. Differential clocks and data strobes ensure exceptional noise immunity for these signals and provide precise crossing points to capture input signals.

### 3.2 Power Management Integrated Circuit Operation

The power management integrated circuit (PMIC) is new for DDR5. For UDIMMs, JEDEC defines PMIC5100. This operation converts a 5V supply into regulated values for components on the module. The PMIC allows the host to monitor voltage and current via the sideband channel.

The PMIC5100 has one 5V nominal supply input pin from the card edge through VIN\_Bulk. The PMIC has the ability to regulate lower voltages to the HUB which allows external access to read/configure this device prior to the VR ENABLE command. The VIN\_Bulk supply, after the VR ENABLE command, will supply all regulated voltages to the PMIC and DRAM.

By default, the PMIC powers up in I2C mode, and the host can reconfigure to support I3C-basic if needed. Please see the address configuration as below table for the PMIC Address ID (PID), device pin #10.

**Table 6 - PMIC Addressing**

PID Configuration (Pin #10)	PMIC Address ID ( PID )			
	Bit 7	Bit 6	Bit 5	Bit 4
Pin to Vss	1	0	0	1

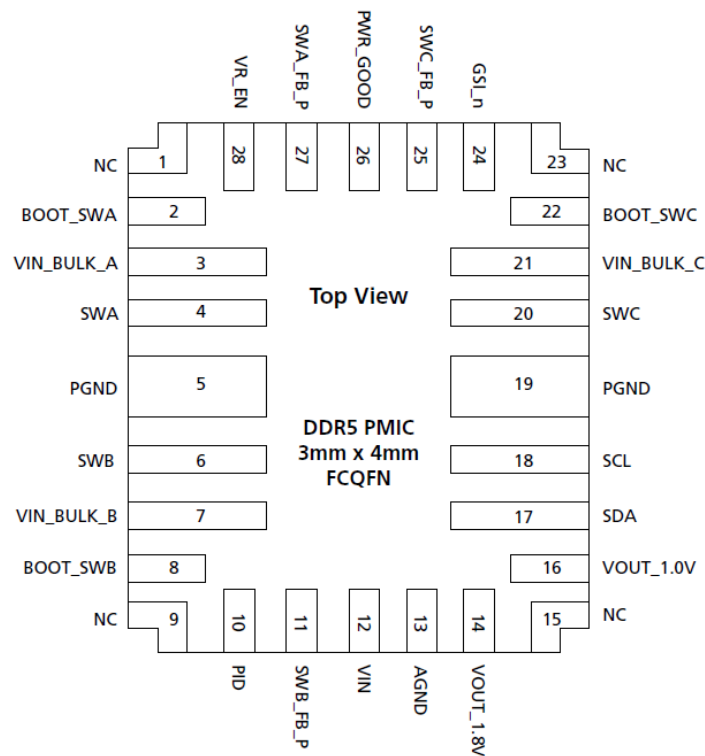

### 3.3 SPD EEPROM HUB Operation

DDR5 SDRAM modules incorporate an SPD EEPROM with hub function with integrated thermal sensor (TS). The SPD data is stored in a 1024-byte including 16 blocks (64 bytes per block), and each block may optionally be write-protected via software command.

The EEPROM resides on a two-wire I3C serial interface, which is also compatible with legacy I2C interface and is not integrated with the memory bus in any manner. It operates as an initiator/target device in the I3C-basic protocol, with all operations synchronized by the serial clock. Transfer rates of up to 12.5 MHz are achievable at 1.0V (NOM).

The first 640 bytes are programmed by UnilC for DIMM parameters related usage. The remaining 384 bytes are available for the end user.

UnilC implements reversible software write protection on DDR5 SDRAM-based modules. This prevents the lower 640 bytes (bytes 0 to 639) from being inadvertently programmed or corrupted. The upper 384 bytes remain available for customer use and are unprotected.

**Table 7 - SPD Byte Information**

Block	Range		Description
0	0~63	0x000~0x03F	Base configuration and DRAM parameters
1	64~127	0x040~0x07F	Base configuration and DRAM parameters
2	128~191	0x080~0x0BF	Reserved for future use
3	192~239	0x0C0~0x0EF	Common Module Parameters -- See annex A.0 for details
	240~255	0x0D0~0x0FF	Standard module parameters -- See annexes A.x for details
4	256~319	0x100~0x13F	Standard module parameters -- See annexes A.x for details
5	320~383	0x140~0x17F	Standard module parameters -- See annexes A.x for details
6	384~447	0x180~0x1BF	Standard module parameters -- See annexes A.x for details
7	448~509	0x1C0~0x1FF	Reserved for future use
	510~511	0x1FE~0x1FF	CRC for SPD bytes 0~509
8	512~575	0x200~0x23F	Manufacturing information
9	576~639	0x240~0x27F	Manufacturing information
10	640~703	0x280~0x2BF	End user programmable
11	704~767	0x2C0~0x2FF	End user programmable
12	768~831	0x300~0x33F	End user programmable
13	832~895	0x340~0x37F	End user programmable
14	896~959	0x380~0x3BF	End user programmable
15	960~1023	0x3C0~0x3FF	End user programmable

### 3.4 Function Block Diagram

Figure 1 - Function Block Diagram\_SCA16GU03C2F1C-56B

#### Channel A

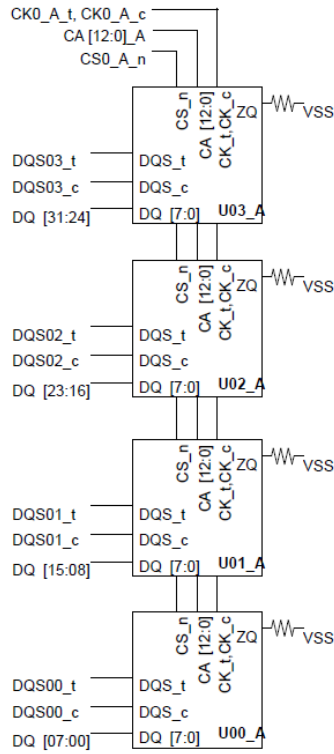

#### Channel B

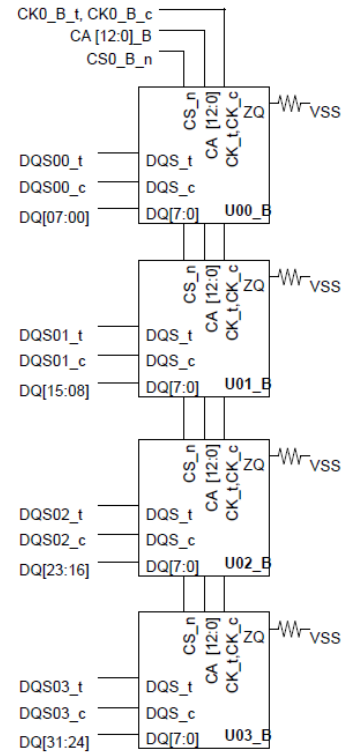

Note 1: ZQ resistors are  $240 \Omega \pm 1\%$ .

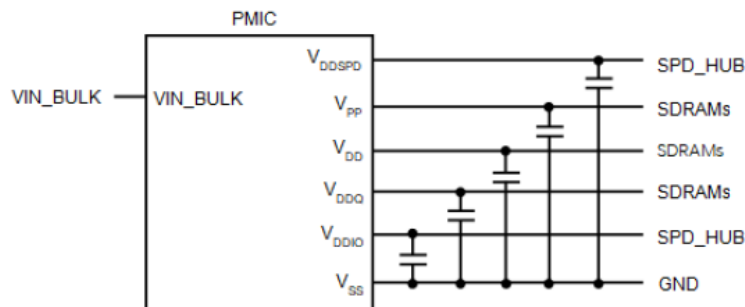
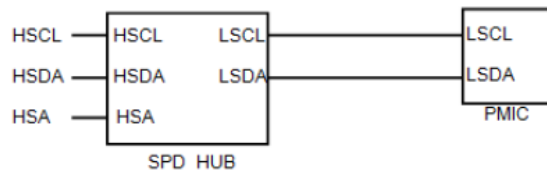

### 3.5 DQ Map

Table 8 - DQ Map \_SCA16GU03C2F1C-56B

Module Pin NO.	Module DQ	IC NO.	IC DQ	Module Pin NO.	Module DQ	IC NO.	IC DQ
9	0_A	U00_A	1	20	8_A	U01_A	1
11	1_A		2	22	9_A		2
154	2_A		3	164	10_A		3
156	3_A		0	166	11_A		0
16	4_A		5	26	12_A		5
18	5_A		6	28	13_A		6
160	6_A		7	171	14_A		7
162	7_A		4	173	15_A		4
30	16_A	U02_A	1	41	24_A	U03_A	1
32	17_A		2	43	25_A		2
175	18_A		3	185	26_A		3
177	19_A		0	187	27_A		0
37	20_A		5	47	28_A		5
39	21_A		6	49	29_A		6
181	22_A		7	192	30_A		7
183	23_A		4	194	31_A		4
101	0_B	U00_B	1	112	8_B	U01_B	1
103	1_B		2	114	9_B		2
246	2_B		3	256	10_B		3
248	3_B		0	258	11_B		0
108	4_B		5	118	12_B		5
110	5_B		6	120	13_B		6
252	6_B		7	263	14_B		7
254	7_B		4	265	15_B		4
122	16_B	U02_B	1	133	24_B	U03_B	1
124	17_B		2	135	25_B		2
267	18_B		3	277	26_B		3
269	19_B		0	279	27_B		0
129	20_B		5	139	28_B		5
131	21_B		6	141	29_B		6
273	22_B		7	284	30_B		7
275	23_B		4	286	31_B		4

## 4 Electrical Characteristics

### 4.1 AC and DC Operation Conditions

**Table 9 - Absolute Maximum DC Ratings**

Symbol	Parameter	Rating		Unit	Note
		Min.	Max.		
$V_{DD}$	Voltage on $V_{DD}$ pin relative to $V_{SS}$	-0.3	+1.4	V	1)
$V_{DDQ}$	Voltage on $V_{DDQ}$ pin relative to $V_{SS}$	-0.3	+1.4	V	1)
$V_{PP}$	Voltage on $V_{PP}$ pin relative to $V_{SS}$	-0.3	+2.1	V	3)
$V_{IN}, V_{OUT}$	Voltage on any pin relative to $V_{SS}$	-0.3	+1.4	V	1)
$T_{STG}$	Storage Temperature	-55	+100	°C	1),2)

Notes:

- 1) Stresses greater than those listed in this table may cause permanent damage to the device. This is a stress rating only and functional operation of the device at these or any other conditions above those indicated in the operational sections of this specification is not implied. Exposure to absolute maximum rating conditions for extended periods may affect reliability.
- 2) Storage temperature is the case surface temperature on the center/top side of the device. For the measurement conditions, refer to JESD51-2 standard.
- 3)  $V_{PP}$  must be equal or greater than  $V_{DD} / V_{DDQ}$  at all times during power on and operation of DRAM device.

**Table 10 - DC Voltage Operating Conditions**

Symbol	Parameter	Low Frequency Voltage Spec			Unit	Note
		Min.	Typ	Max.		
$V_{DD}$	Voltage on $V_{DD}$ pin relative to $V_{SS}$	1.067(-3%)	1.1	1.166(+6%)	V	1), 2)
$V_{DDQ}$	Voltage on $V_{DDQ}$ pin relative to $V_{SS}$	1.067(-3%)	1.1	1.166(+6%)	V	1), 2)
$V_{PP}$	Voltage on $V_{PP}$ pin relative to $V_{SS}$	1.746(-3%)	1.8	1.908(+6%)	V	1), 2)

Notes:

- 1)  $V_{DD}$  must be within 66mV of  $V_{DDQ}$ .
- 2) AC parameters are measured with  $V_{DD}$  and  $V_{DDQ}$  tied together.

**Table 11 - DRAM Component Operating Temperature Range**

Symbol	Parameter	Rating		Unit	Grade	Note
		Min.	Max.			
$T_{\text{OPER\_NORMAL}}$	Normal Operating Temperature	0	85	°C	NT	1),2),3),4)
$T_{\text{OPER\_EXTENDED}}$	Extended Operating Temperature	0	95	°C	XT	1),2),3),4)

Notes:

- 1) All operating temperature symbols, ranges, acronyms from JESD402-1.
- 2) Operating Temperature is the case surface temperature on the center / top side of the DRAM. For the measurement conditions, refer to JESD51-2.
- 3) All devices are required to operate in NT and XT temperature ranges.
- 4) When operating above 85°C , the host shall provide appropriate refresh mode controls associated with increased temperature range. The full description of these settings are defined in the tREFI parameters for REFab and REFsb command by device density table in the Refresh operations section (DRAM datasheet).

## 4.2 Module and Component Speed Grades

DDR5 components may exceed the listed module speed grades; module may not be available in all listed speed grades

**Table 12 - Module and Component Speed Grades**

<b>Module Speed Grade</b>	<b>Component Speed Grade</b>
-56B	5600-46-45-45

## 4.3 I<sub>DD</sub> Specifications

**Table 13 - I<sub>DD</sub> Specification for SCA16GU03C2F1C-56B**

Module IDD is based on PMIC VIN\_BULK 5V input current and typical operating temperature. Each IDD parameter includes PMIC efficiency and all DRAM current on all supplies (VDD, VDDQ and VPP).

Product Type		SCA16GU03C2F1C-56B		
Organization		16GB	Unit	Note
		1Rank (×8)		
		×64		
		-56B		
Parameter	Symbol	Current		
Operating one bank ACTIVATE-PRECHARGE current	IDD0	181	mA	
Operating four bank ACTIVATE-PRECHARGE current	IDD0F	270	mA	
Precharge standby current	IDD2N	148	mA	
Precharge power-down current	IDD2P	68	mA	
Active standby current	IDD3N	232	mA	
Active power-down current	IDD3P	72	mA	
Operating burst read current	IDD4R	635	mA	
Operating burst write current	IDD4W	589	mA	
Burst refresh (normal refresh mode) current	IDD5B	562	mA	
Burst refresh (fine granularity refresh mode) current	IDD5F	529	mA	
Burst refresh (same bank refresh mode) current	IDD5C	281	mA	
Self refresh current	IDD6N	43	mA	
Operating bank interleave read current	IDD7	911	mA	
Maximum power saving deep power down mode current	IDD8	16	mA	

## 5 Package Dimensions

Figure 2 - Package Dimensions\_SCA16GU03C2F1C-56B

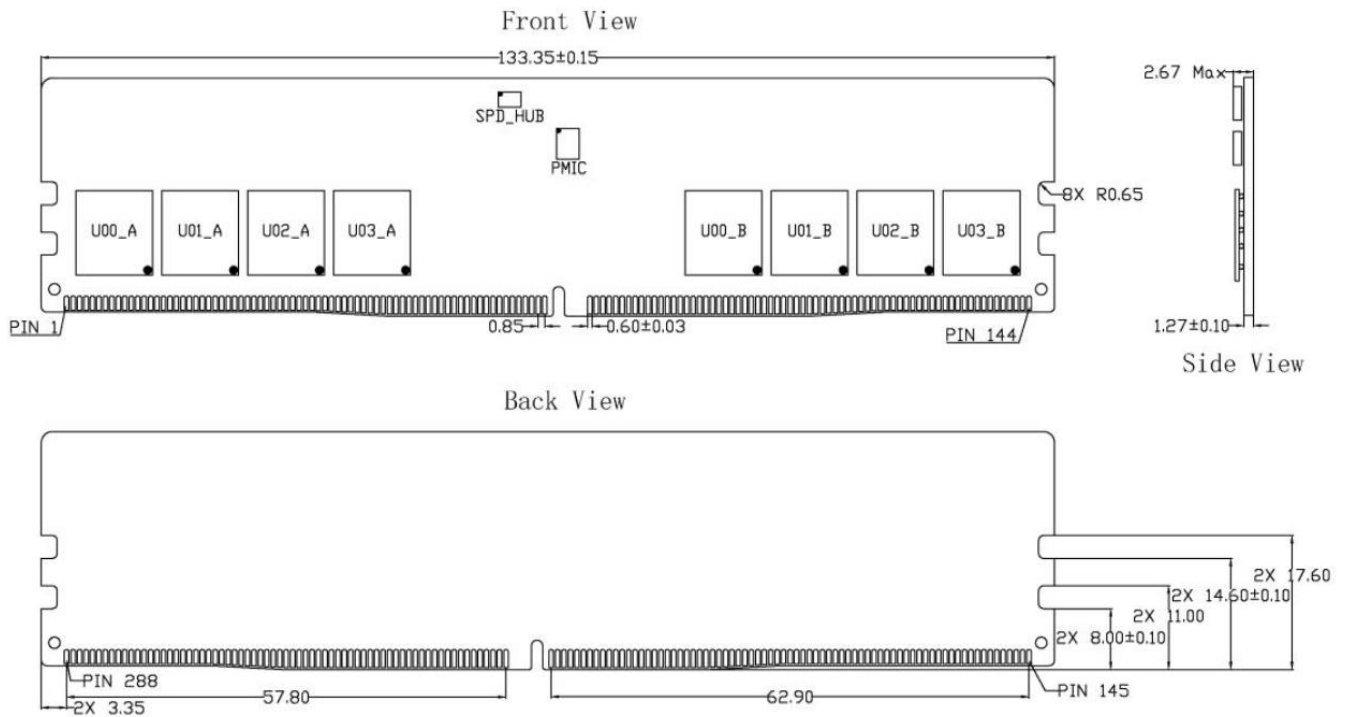

- Note:
1. All dimensions are in millimeters.
  2. The dimensional diagram is for reference only.

## List of Figures

Figure 1 - Function Block Diagram_SCA16GU03C2F1C-56B .....	13
Figure 2 - Package Dimensions_SCA16GU03C2F1C-56B.....	19

## List of Tables

Table 1 - Module Performance Table.....	4
Table 2 - Ordering Information.....	5
Table 3 - Address Format .....	5
Table 4 - Pin Configuration UDIMM (288 pin).....	6
Table 5 - Pin Descriptions.....	8
Table 6 - PMIC Addressing.....	11
Table 7 - SPD Byte Information .....	12
Table 8 - DQ Map _SCA16GU03C2F1C-56B.....	14
Table 9 - Absolute Maximum DC Ratings .....	15
Table 10 - DC Voltage Operating Conditions .....	15
Table 11 - DRAM Component Operating Temperature Range.....	16
Table 12 - Module and Component Speed Grades .....	17
Table 13 - I <sub>DD</sub> Specification for SCA16GU03C2F1C-56B .....	18

**Edition 2025-02**  
**Published by**  
**Xi'an UnilC Semiconductors Co., Ltd.**

**Xi'an: 4th Floor, Building A,**  
**No. 38 Gaoxin 6th Road,**  
**Xian High-tech Industries Development Zone**  
**Xi'an, Shaanxi 710075, P. R. China**  
**Tel: +86-29-88318000**  
**Fax: +86-29-88453299**

**info@unisemicon.com**

**© UnilC 2025.**  
**All Rights Reserved.**

#### **Legal Disclaimer**

THE INFORMATION GIVEN IN THIS INTERNET DATA SHEET SHALL IN NO EVENT BE REGARDED AS A GUARANTEE OF CONDITIONS OR CHARACTERISTICS. WITH RESPECT TO ANY EXAMPLES OR HINTS GIVEN HEREIN, ANY TYPICAL VALUES STATED HEREIN AND/OR ANY INFORMATION REGARDING THE APPLICATION OF THE DEVICE, UNILC HEREBY DISCLAIMS ANY AND ALL WARRANTIES AND LIABILITIES OF ANY KIND, INCLUDING WITHOUT LIMITATION WARRANTIES OF NON-INFRINGEMENT OF INTELLECTUAL PROPERTY RIGHTS OF ANY THIRD PARTY.

#### **Information**

For further information on technology, delivery terms and conditions and prices please contact your nearest UnilC Office.

#### **Warnings**

Due to technical requirements components may contain dangerous substances. For information on the types in question please contact your nearest UnilC Office.

UnilC Components may only be used in life-support devices or systems with the express written approval of UnilC, if a failure of such components can reasonably be expected to cause the failure of that life-support device or system, or to affect the safety or effectiveness of that device or system. Life support devices or systems are intended to be implanted in the human body, or to support and/or maintain and sustain and/or protect human life. If they fail, it is reasonable to assume that the health of the user or other persons may be endangered.

[www.unisemicon.com](http://www.unisemicon.com)